

GENERAL FEATURES OF THE TECHNORAIL STAGING/PLATFORM UNITS

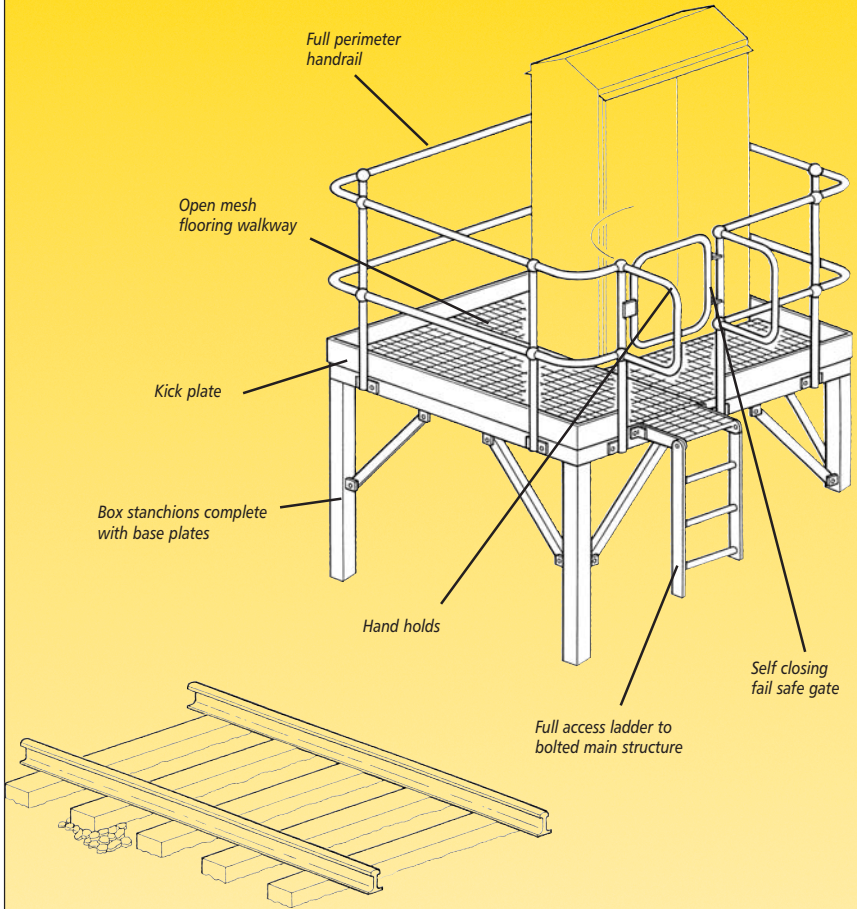

- WIDTH X DEPTH X HEIGHT TO SUIT SITE REQUIREMENTS •
- FULL FRAME AND INTERMEDIATE SUPPORT MEMBERS WHERE REQUIRED •
- MANUFACTURED FROM MINIMUM 4 MM STEEL PLATE •
- HOT DIP GALVANISED AFTER MANUFACTURE TO BS EN ISO 1461 •

TYPE STG/1**PRODUCT USES**

Standard modular staging for a single half or full location cabinet. Units are made to suit "up or down bank" situations, also stage situation where raising the location cabinet is necessary due to flood prone areas.

STANDARD PRODUCT FEATURES

- Standard 1900mm width x 1900mm depth x height depending on site conditions & requirements. (Non standard sizes available on request)
- Half or Full location cabinet footprint fixing holes to front or back as required
- Stanchions with base plate supplied to suit specific site requirements
- Full open mesh flooring walkway complete with fixings to BS 4592
- Full perimeter tubular handrailing & stanchions to BS 5395
- Self closing, inward opening fail safe gate to BS 5395
- Full access ladder complete with hand hold to BS 4211 & BS 5395
- All components Hot dip galvanised after manufacture to BS EN ISO 1461
- Optional Supply & fit available from TechnoRail trained fitting teams including full site survey

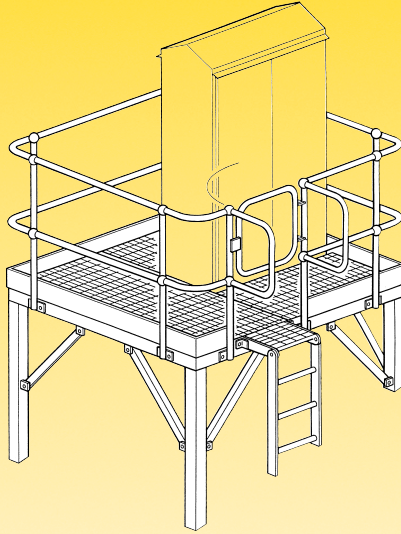
MODULAR STAGING UNIT-SINGLE**AVAILABILITY**

Delivery is normally within 3 weeks (or to clients requirements) from receipt of order and is generally supplied direct to site or supply & fit.

ACCESSORIES

- | | |
|------|---|
| /D1 | Identification marking (please specify) |
| /FTH | Fire tray (half Loc) |
| /FTF | Fire tray (full Loc) |
| /S&F | Supply & fit |

HOW TO ORDER/SPECIFY

Progression example for specifying

1. Select Product Reference: STG/1
2. Add accessory i.e. /FTH Fire Tray-Half Loc

Full reference: STG/1/FTH

NOTE: Location cabinet footprint position, ladder/gate position & leg length etc to be confirmed prior to manufacture.

**SECTION/PLAN DETAILS**