

## SECURITY AND GENERAL FEATURES OF THE TECHNORAIL ULTRASECURE CASE/CABINET RANGE

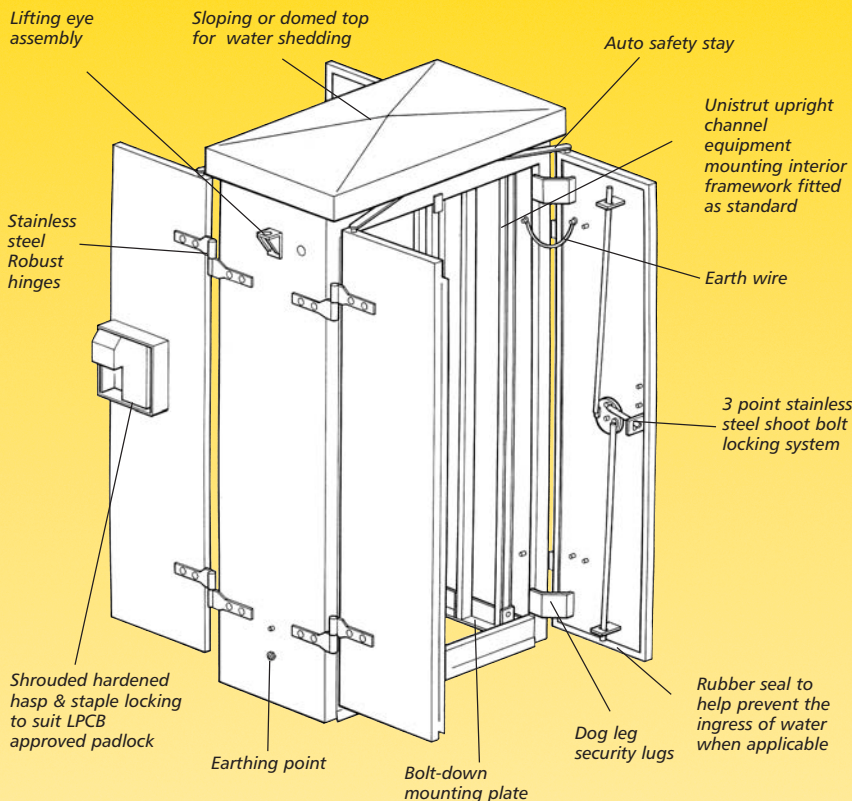

- ALL CABINETS CAN BE MADE TO SUIT INDIVIDUAL CUSTOMER REQUIREMENTS •
  - **LPCB SECURITY RATING APPROVED, LOCATION APPARATUS PRODUCTS** •
- LARGER CABINETS HAVE THE FACILITY TO BE TAKEN TO SITE IN A FLAT PACK SYSTEM FOR EASE OF SITE ASSEMBLY •
  - **LASER CUT IDENTIFICATION TO CUSTOMER REQUIREMENTS** •
  - **LOUVRE VENTS ACCESSORY POSITIONED WHERE REQUIRED** •
  - **HOT DIP GALVANISED AFTER MANUFACTURE TO BS EN ISO 1461** •
- EXTERNAL PAINT FINISHES ARE AVAILABLE FOR AESTHETIC APPEARANCE IF REQUIRED •
  - **ALTERNATIVE MATERIALS AVAILABLE ON REQUEST** •

## TYPE THB

### PRODUCT USES

Housing box for lineside telephones to deter delinquents, vandals, etc. Prevents continual replacement of expensive phone sets.

### STANDARD PRODUCT FEATURES

- Standard size: 500mm Height x 400mm Width x 250mm Deep
- BR1 lock fitted as standard
- 4 fixing holes to rear plate as standard
- Plywood backboard as standard
- Internal bolt fixings for security
- Sealing strip to door
- Manufactured from minimum 3mm steel plate
- Hot dip galvanised after manufacture to BS EN ISO 1461
- External paint finishes are available for aesthetic appearance if required and will be applied over etch primer and base coat
- Alternative materials available on request
- Optional support post (see accessories)
- Security level 2 to combat Trespass and Vandalism

### AVAILABILITY

Delivery is normally within 3 weeks (or to clients requirements) from receipt of order and is generally supplied direct to site or supply & fit.

### ACCESSORIES

- /D1 Identification marking (please specify)
- /HL Door hinged left (hinged right as standard)
- /XP External paint colour (please specify)
- /RCP Rear cabinet post (see ancillaries, section 5, page 2)
- /RCPC Rear cabinet post cable entry (see ancillaries, section 5, page 2)
- /BCP Bottom cabinet post (see ancillaries, section 5, page 2)
- /BCPC Bottom cabinet post cable entry (see ancillaries, section 5, page 2)

### HOW TO ORDER/SPECIFY

Progression example for specifying:

1. Product Type: THB
2. Add accessory: i.e. /RCPC - Rear cabinet post cable entry

Full reference: THB/RCPC

# ULTRASECURE TELEPHONE HOUSING BOX

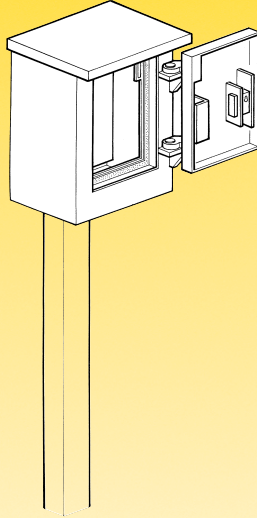

## SECTION/PLAN DETAILS

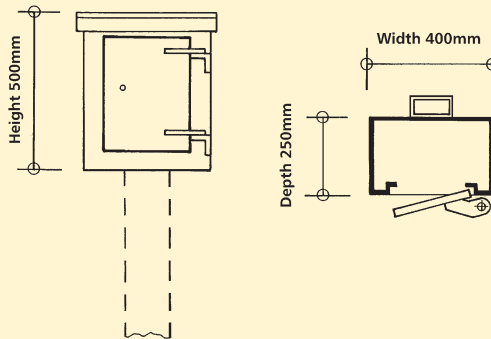

01/07/03

ALL TECHNICAL DETAILS ARE COPYRIGHT, AND MUST NOT BE REPRODUCED WITHOUT PRIOR CONSENT