

SECURITY AND GENERAL FEATURES OF THE TECHNORAIL ULTRASECURE CASE/CABINET RANGE

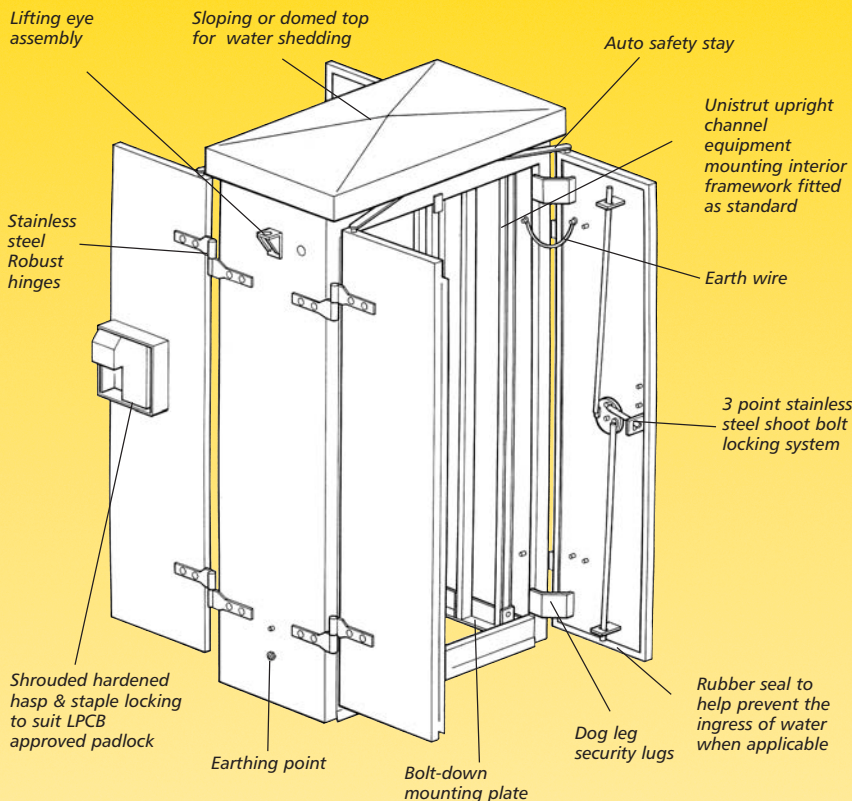

- ALL CABINETS CAN BE MADE TO SUIT INDIVIDUAL CUSTOMER REQUIREMENTS •
 - **LPCB SECURITY RATING APPROVED, LOCATION APPARATUS PRODUCTS** •
- LARGER CABINETS HAVE THE FACILITY TO BE TAKEN TO SITE IN A FLAT PACK SYSTEM FOR EASE OF SITE ASSEMBLY •
 - **LASER CUT IDENTIFICATION TO CUSTOMER REQUIREMENTS** •
 - **LOUVRE VENTS ACCESSORY POSITIONED WHERE REQUIRED** •
 - **HOT DIP GALVANISED AFTER MANUFACTURE TO BS EN ISO 1461** •
- EXTERNAL PAINT FINISHES ARE AVAILABLE FOR AESTHETIC APPEARANCE IF REQUIRED •
 - **ALTERNATIVE MATERIALS AVAILABLE ON REQUEST** •

VARIATIONS OF TECHNORAIL ULTRASECURE CABINET RANGE

• **TYPICAL SPECIALS** •

TWIN DOOR GENERAL EQUIPMENT MODULAR CABINET

Previously supplied to house fuel pump switches & meters, but can be used for various other applications

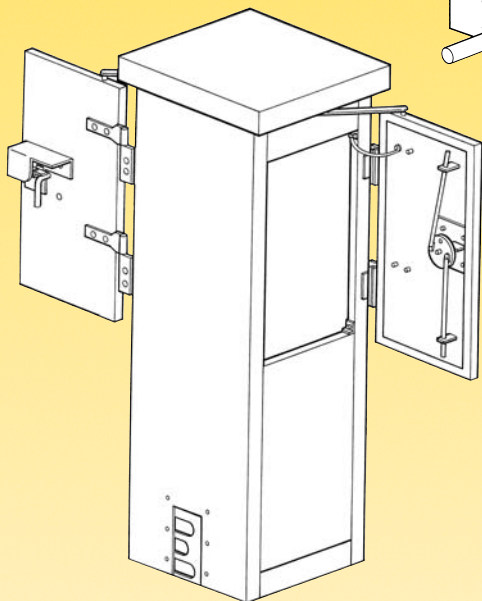
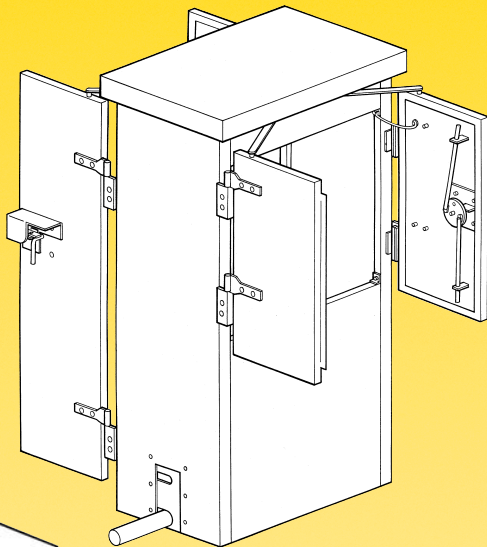

SINGLE DOOR GENERAL EQUIPMENT MODULAR CABINET

Single door version of above showing flexibility in design, having various combinations of door sizes and cable entry points for electrical services - specially designed to fit around existing equipment plus many other variations to suit customer requirements