

## SECURITY AND GENERAL FEATURES OF THE TECHNORAIL ULTRASECURE CASE/CABINET RANGE

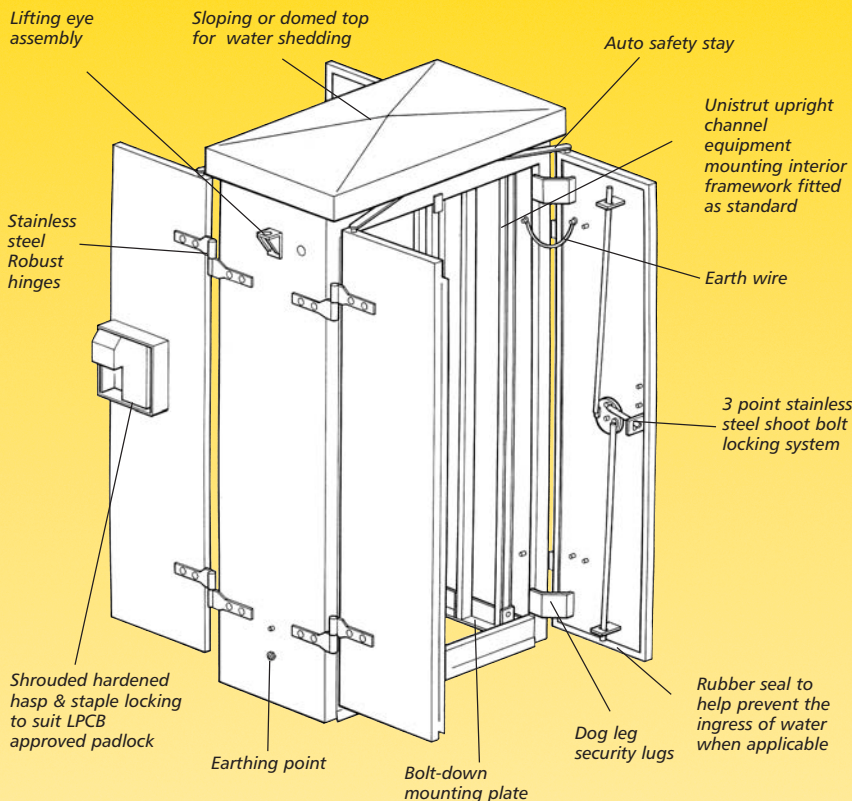

- ALL CABINETS CAN BE MADE TO SUIT INDIVIDUAL CUSTOMER REQUIREMENTS •
  - *LPCB SECURITY RATING APPROVED, LOCATION APPARATUS PRODUCTS* •
- LARGER CABINETS HAVE THE FACILITY TO BE TAKEN TO SITE IN A FLAT PACK SYSTEM FOR EASE OF SITE ASSEMBLY •
  - *LASER CUT IDENTIFICATION TO CUSTOMER REQUIREMENTS* •
  - *LOUVRE VENTS ACCESSORY POSITIONED WHERE REQUIRED* •
  - *HOT DIP GALVANISED AFTER MANUFACTURE TO BS EN ISO 1461* •
- EXTERNAL PAINT FINISHES ARE AVAILABLE FOR AESTHETIC APPEARANCE IF REQUIRED •
  - *ALTERNATIVE MATERIALS AVAILABLE ON REQUEST* •

## TYPE SCCM/H

### PRODUCT USES

UltraSecure mounted case for storage of up to 3 switch clamps and scotches.

### STANDARD PRODUCT FEATURES

- Standard size - 620mm Height x 470mm Width x 320mm Depth
- Deep, well drained box
- Shrouded Hasp and Staple Locking to suit Railtrack approved padlock
- Internal hanging rail for clamps
- Secure door hinged right as standard
- 4 fixing holes to rear plate as standard
- Manufactured from minimum 3mm steel plate
- Hot dip galvanised after manufacture to BS EN ISO 1461
- External paint finishes are available for aesthetic appearance if required and will be applied over etch primer and base coat
- Alternative materials available on request
- Optional support post (see accessories)
- Security level 2 to combat Trespass and Vandalism

### AVAILABILITY

Delivery is normally within 3 weeks (or to clients requirements) from receipt of order and is generally supplied direct to site or supply & fit.

### ACCESSORIES

- /D1 Identification marking (please specify)
- /HL Door hinged left (hinged right as standard)
- /YB Yellow band
- /YL Yellow lid
- /XP External paint colour (please specify)
- /RCP Rear cabinet post (see ancillaries, section 5, page 2)
- /BCP Bottom cabinet post (see ancillaries, section 5, page 2)

### HOW TO ORDER/SPECIFY

Progression example for specifying

1. Select Product Reference: SCCM/H
2. Add accessory: i.e. /YB - Yellow band

Full reference: SCCM/H/YB

## ULTRASECURE SWITCH CLAMP CASE WALL/POST MOUNTED-HALF

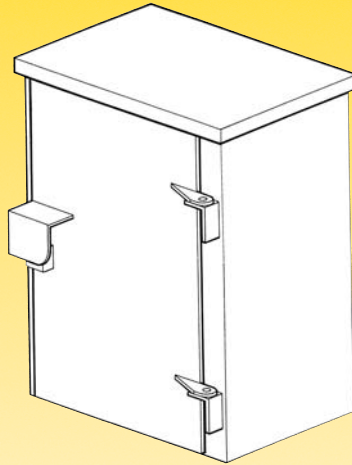

## SECTION/PLAN DETAILS

