

SECURITY AND GENERAL FEATURES OF THE TECHNORAIL ULTRASECURE CASE/CABINET RANGE

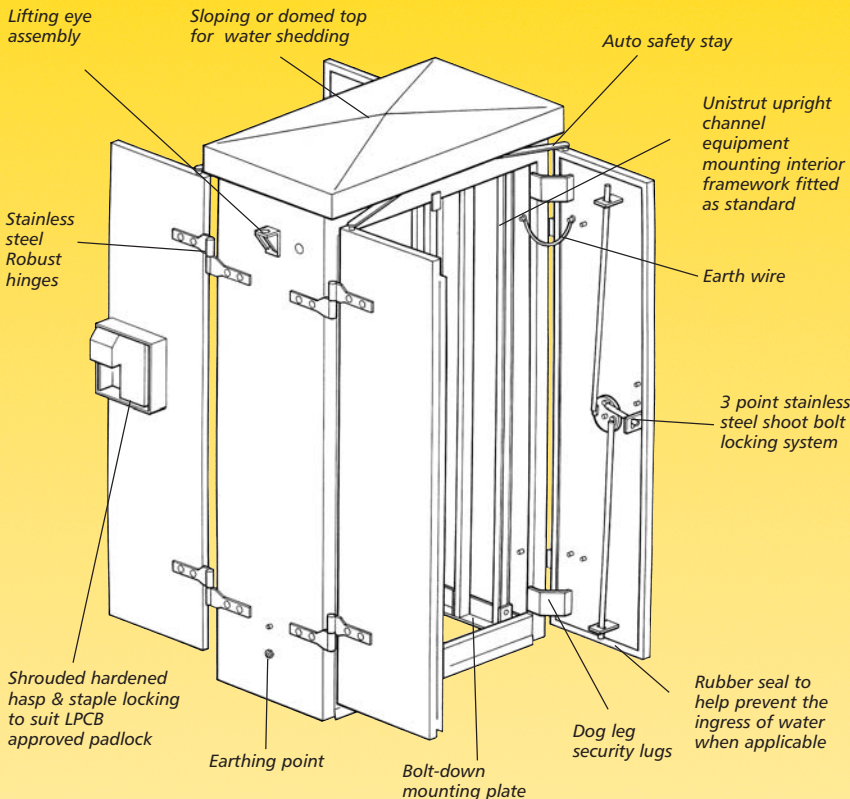

- ALL CABINETS CAN BE MADE TO SUIT INDIVIDUAL CUSTOMER REQUIREMENTS •
 - **LPCB SECURITY RATING APPROVED, LOCATION APPARATUS PRODUCTS** •
- LARGER CABINETS HAVE THE FACILITY TO BE TAKEN TO SITE IN A FLAT PACK SYSTEM FOR EASE OF SITE ASSEMBLY •
 - **LASER CUT IDENTIFICATION TO CUSTOMER REQUIREMENTS** •
 - **LOUVRE VENTS ACCESSORY POSITIONED WHERE REQUIRED** •
 - **HOT DIP GALVANISED AFTER MANUFACTURE TO BS EN ISO 1461** •
- EXTERNAL PAINT FINISHES ARE AVAILABLE FOR AESTHETIC APPEARANCE IF REQUIRED •
 - **ALTERNATIVE MATERIALS AVAILABLE ON REQUEST** •

TYPE SCC/H

PRODUCT USES

UltraSecure case for storage of up to 3 switch clamps and scotches.

STANDARD PRODUCT FEATURES

- Standard size - 900mm Height x 450mm Width x 440mm Depth
- Deep, well drained box
- Shrouded Hasp and Staple Locking to suit Railtrack approved padlock
- Internal hanging rail for clamps
- Secure lid with hidden hinges
- Bolt holes in base flanges for floor fixing.
- Fixing hole centres match standard concrete location base
- Manufactured from minimum 3mm steel plate
- Hot dip galvanised after manufacture to BS EN ISO 1461
- External paint finishes are available for aesthetic appearance if required and will be applied over etch primer and base coat
- Alternative materials available on request
- Security level 2 to combat Trespass and Vandalism

AVAILABILITY

Delivery is normally within 3 weeks (or to clients requirements) from receipt of order and is generally supplied direct to site or supply & fit.

ACCESSORIES

- /D1 Identification marking (please specify)
- /YB Yellow band
- /YL Yellow lid
- /XP External paint colour (please specify)
- /CB Concrete base

HOW TO ORDER/SPECIFY

Progression example for specifying

1. Select Product Reference: SCC/H
2. Add accessory: i.e. /YB - Yellow band

Full reference: SCC/H/YB

ULTRASECURE SWITCH CLAMP CASE-HALF

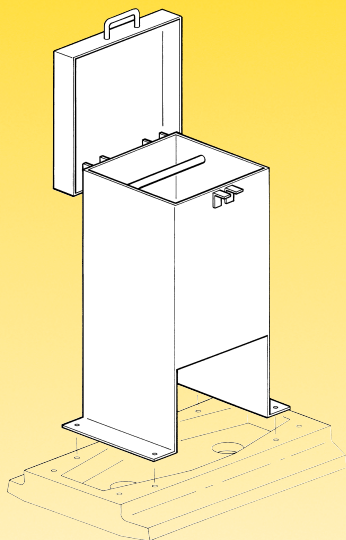

SECTION/PLAN DETAILS

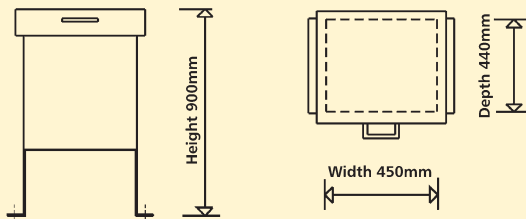

01/07/03

ALL TECHNICAL DETAILS ARE COPYRIGHT, AND MUST NOT BE REPRODUCED WITHOUT PRIOR CONSENT