

## SECURITY AND GENERAL FEATURES OF THE TECHNORAIL ULTRASECURE CASE/CABINET RANGE

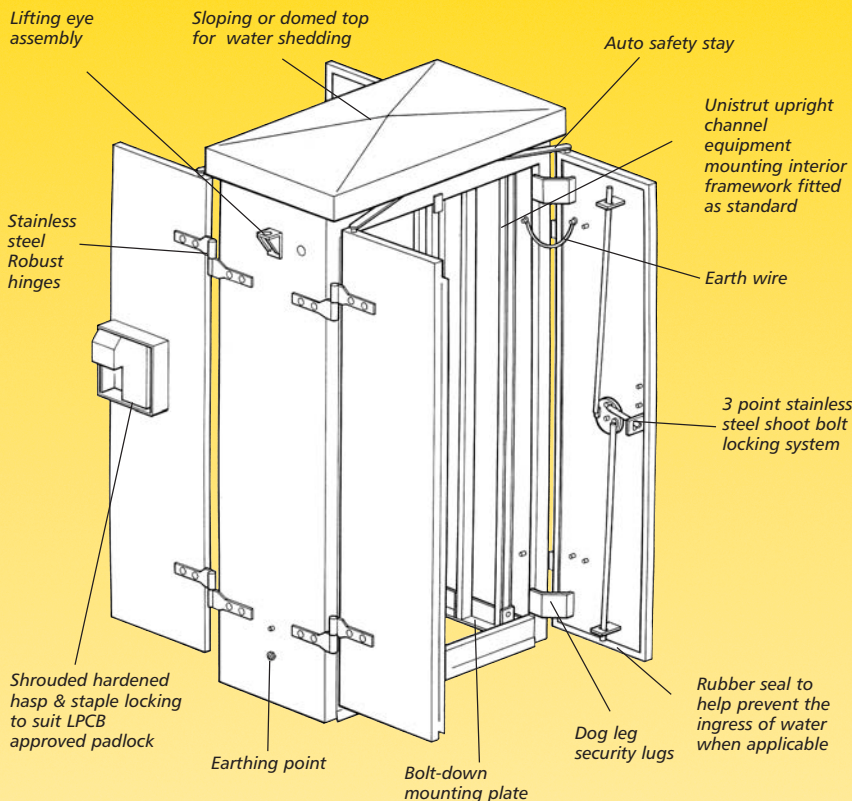

- ALL CABINETS CAN BE MADE TO SUIT INDIVIDUAL CUSTOMER REQUIREMENTS •
  - **LPCB SECURITY RATING APPROVED, LOCATION APPARATUS PRODUCTS** •
- LARGER CABINETS HAVE THE FACILITY TO BE TAKEN TO SITE IN A FLAT PACK SYSTEM FOR EASE OF SITE ASSEMBLY •
  - **LASER CUT IDENTIFICATION TO CUSTOMER REQUIREMENTS** •
  - **LOUVRE VENTS ACCESSORY POSITIONED WHERE REQUIRED** •
  - **HOT DIP GALVANISED AFTER MANUFACTURE TO BS EN ISO 1461** •
- EXTERNAL PAINT FINISHES ARE AVAILABLE FOR AESTHETIC APPEARANCE IF REQUIRED •
  - **ALTERNATIVE MATERIALS AVAILABLE ON REQUEST** •

# ULTRASECURE REPLACEMENT OF GRP/FIBREGLASS APPARATUS CASE/POWER LOC (NON POSSESSION FIT)

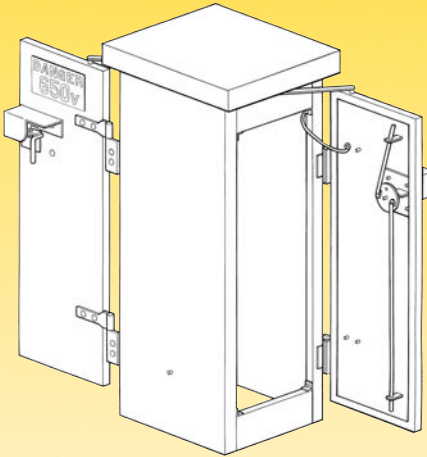

## TYPE RGAC/P

### PRODUCT USES

A uniquely designed modular replacement "wrap around" enhanced security case to replace old, damaged and/or worn out GRP/Fibreglass power loc's, whilst leaving the equipment mounting interior framework in place. This case can be installed without the need for track possession by TechnoRail qualified fitters under PADS approval No. PA 05/802.

### STANDARD PRODUCT FEATURES

- Standard size - 1430mm Height x 470mm Width x 560 Depth
- Front & back opening doors
- 2 point stainless steel shoot bolt shrouded locking system
- Hardened Hasp and Staple locking to suit Rail Industry approved padlock
- Auto door safety stays 90° and 135° openings
- Manufactured from minimum 3mm steel plate
- Hot dip galvanised after manufacture to BS EN ISO 1461
- Security level 2 to combat Trespass and Vandalism
- "Danger 650v" plating fitted as standard

### AVAILABILITY

Supply & fit is normally within 3 weeks (or to clients requirements) from receipt of order.

### ACCESSORIES

- /D1 Identification marking (please specify)
- /XP External paint colour for aesthetic appearance (please specify)

### HOW TO ORDER/SPECIFY

- Progression example for specifying
1. Select Product Reference: RGAC/P
  2. Add accessory: i.e. /D1(1234) - Identification marking

*Full reference: RGAC/P/D1(1234)*



## SECTION/PLAN DETAILS

