

SECURITY AND GENERAL FEATURES OF THE TECHNORAIL ULTRASECURE CASE/CABINET RANGE

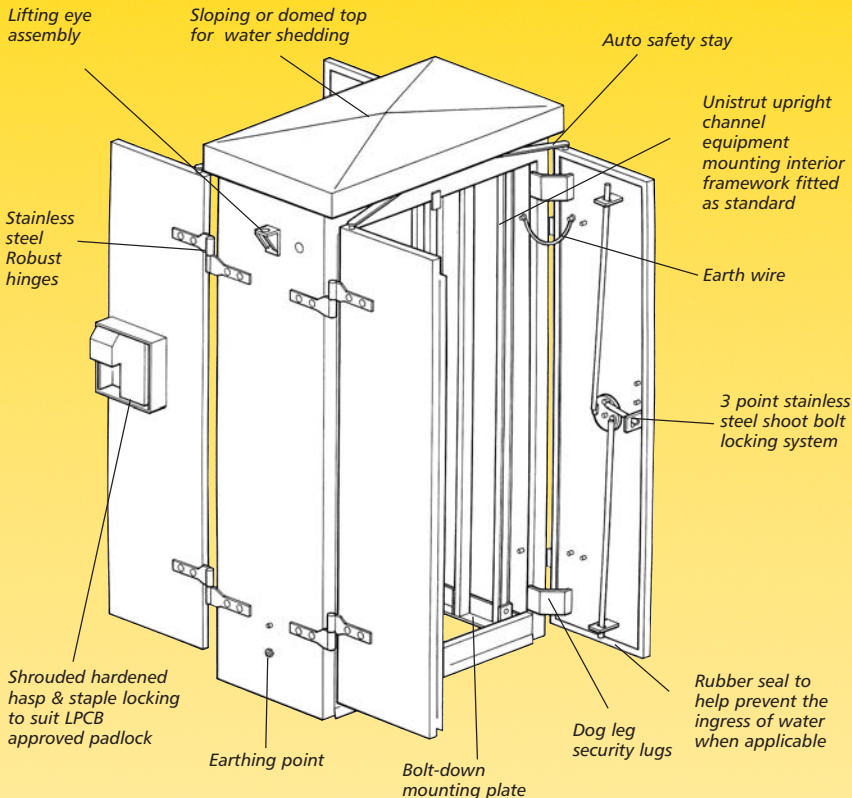

- ALL CABINETS CAN BE MADE TO SUIT INDIVIDUAL CUSTOMER REQUIREMENTS •
 - **LPCB SECURITY RATING APPROVED, LOCATION APPARATUS PRODUCTS** •
- LARGER CABINETS HAVE THE FACILITY TO BE TAKEN TO SITE IN A FLAT PACK SYSTEM FOR EASE OF SITE ASSEMBLY •
 - **LASER CUT IDENTIFICATION TO CUSTOMER REQUIREMENTS** •
 - **LOUVRE VENTS ACCESSORY POSITIONED WHERE REQUIRED** •
 - **HOT DIP GALVANISED AFTER MANUFACTURE TO BS EN ISO 1461** •
- EXTERNAL PAINT FINISHES ARE AVAILABLE FOR AESTHETIC APPEARANCE IF REQUIRED •
 - **ALTERNATIVE MATERIALS AVAILABLE ON REQUEST** •

TYPE LAC/P/DV4

PRODUCT USES

LPCB approval No. 450b/03-Level 4, high security cases with PADS approval No. PA 05/1040. Designed specifically to cope in areas where *railway crime* is particularly prevalent. Power case is designed to house 650volts power supply and transformers for S & T cases.

STANDARD PRODUCT FEATURES

- Standard Half Location size -1845mm Height x 575mm Width x 485mm Depth
- Front & back opening doors
- 3 point stainless steel shoot bolt shrouded locking system
- Hardened Hasp and Staple locking to suit LPCB approved padlock
- Auto door safety stays 90° and 135° openings
- Stainless steel hinges
- Manufactured from minimum 4mm steel plate
- Hot dip galvanised after manufacture to BS EN ISO 1461
- Unistrut upright channel equipment mounting interior framework fitted as standard
- Internal bolt fixings
- "Danger 650v" plating fitted as standard
- Security level 4 to combat Trespass and Vandalism

AVAILABILITY

Delivery is normally within 3 weeks (or to clients requirements) from receipt of order and is generally supplied direct to site or supply & fit.

ACCESSORIES

- /D1 Identification marking (please specify)
- /XP External paint colour for aesthetic appearance (please specify)

HOW TO ORDER/SPECIFY

- Progression example for specifying
1. Select Product Reference: LAC/P/DV4
 2. Add accessory: i.e. /D1(1234) - Identification marking

Full reference: LAC/P/DV4/D1(1234)

ULTRASECURE LOCATION APPARATUS CASE/POWER LOC

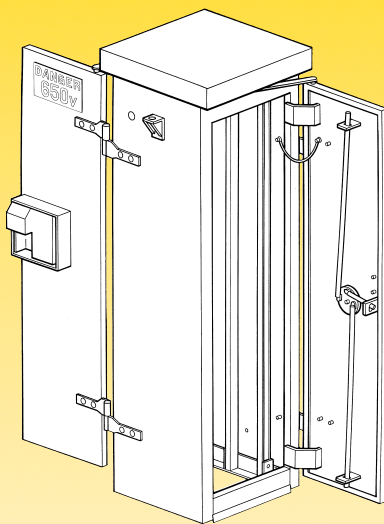

LPCB Approved
Certificate No. 450b/03
Level 4
Security Rating 4
Certificate No. 450b/03

SECTION/PLAN DETAILS

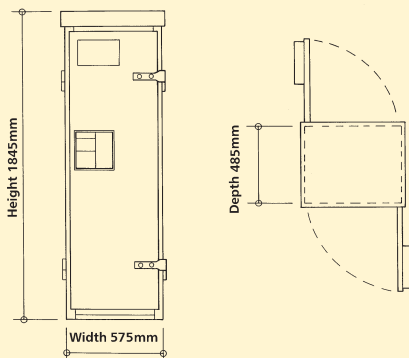

01/07/03

ALL TECHNICAL DETAILS ARE COPYRIGHT, AND MUST NOT BE REPRODUCED WITHOUT PRIOR CONSENT