

# SECURITY AND GENERAL FEATURES OF THE TECHNORAIL ULTRASECURE CASE/CABINET RANGE

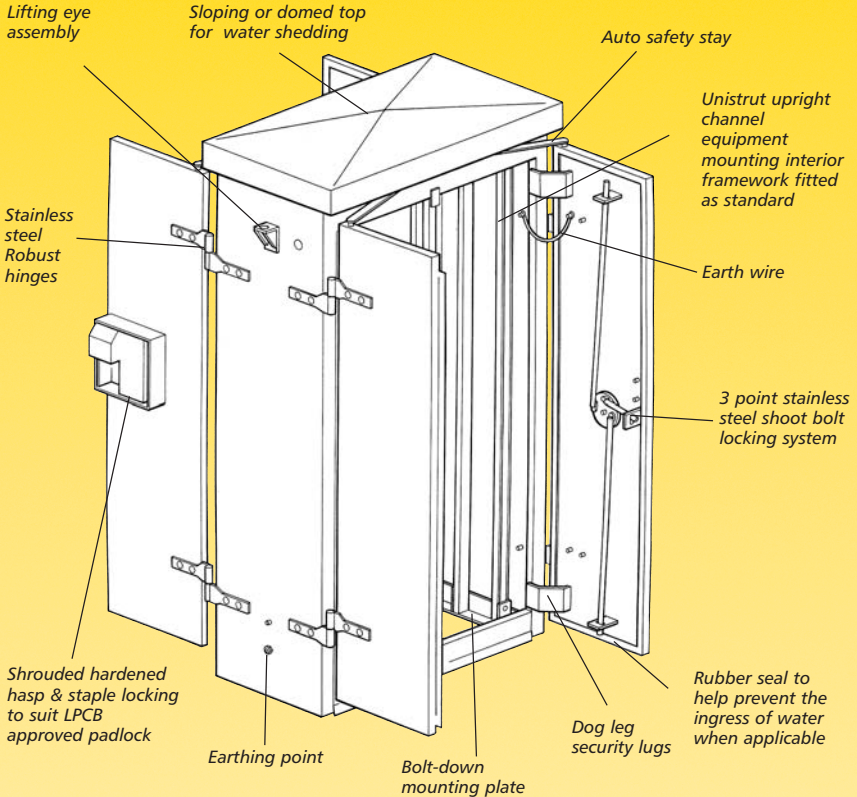

- ALL CABINETS CAN BE MADE TO SUIT INDIVIDUAL CUSTOMER REQUIREMENTS •
  - **LPCB SECURITY RATING APPROVED, LOCATION APPARATUS PRODUCTS** •
- LARGER CABINETS HAVE THE FACILITY TO BE TAKEN TO SITE IN A FLAT PACK SYSTEM FOR EASE OF SITE ASSEMBLY •
  - **LASER CUT IDENTIFICATION TO CUSTOMER REQUIREMENTS** •
  - **LOUVRE VENTS ACCESSORY POSITIONED WHERE REQUIRED** •
  - **HOT DIP GALVANISED AFTER MANUFACTURE TO BS EN ISO 1461** •
- EXTERNAL PAINT FINISHES ARE AVAILABLE FOR AESTHETIC APPEARANCE IF REQUIRED •
  - **ALTERNATIVE MATERIALS AVAILABLE ON REQUEST** •

## TYPE GWP/N

### PRODUCT USES

Replacement door panels for Narrow GWR type location cabinets with PADS approval No. GW/SRG/S/171.

### STANDARD PRODUCT FEATURES

- Standard size: 1026mm Height x 404mm Width
- One hasp & staple locking handle shrouded for extra security
- Locking system to suit RKB221/222 suited padlocks
- Two angles for turnbuckle locks
- 2 No. lifting handles
- Manufactured from minimum 2mm steel plate
- Fixtures hot dip galvanised after manufacture to BS EN ISO 1461
- External paint finishes are available for aesthetic appearance if required and will be applied over etch primer and base coat
- Alternative materials available on request
- Security level 2 to combat Trespass and Vandalism

### AVAILABILITY

Delivery is normally within 3 weeks (or to clients requirements) from receipt of order and is generally supplied direct to site or supply & fit.

### ACCESSORIES

- /D1 Identification marking (please specify)
- /XP External paint colour (please specify)

### HOW TO ORDER/SPECIFY

- Progression example for specifying
1. Select Product Reference: GWP/N
  2. Add accessory: i.e. /D1 (Network Rail)
    - Identification marking

Full reference:

GWP/N/D1 (Network Rail)

## ULTRASECURE GREAT WESTERN DOOR PANEL-NARROW

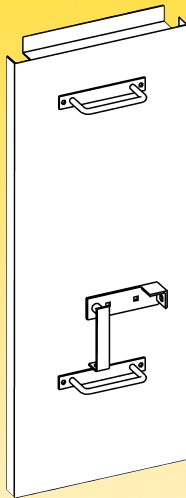

## SECTION/PLAN DETAILS

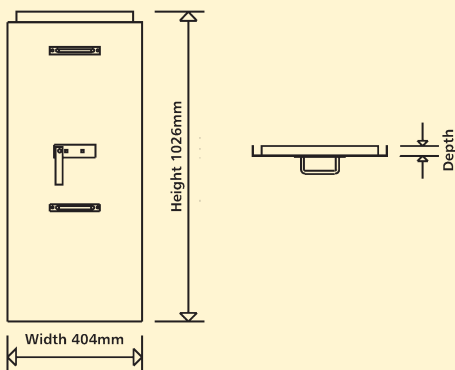

01/07/03

ALL TECHNICAL DETAILS ARE COPYRIGHT, AND MUST NOT BE REPRODUCED WITHOUT PRIOR CONSENT