

# GENERAL FEATURES OF THE TECHNORAIL TEMPORARY SAFETY BARRIER

Main pedestal with removable lid. Pedestal can be bolted down or counterbalanced with internal sandbags (determined by site conditions)

Double sided interchangeable reflective "stop" board signs which can be positioned centrally within any of the aluminium crossbars

Typical crossbar joint having one vertical and two horizontal connection bolts

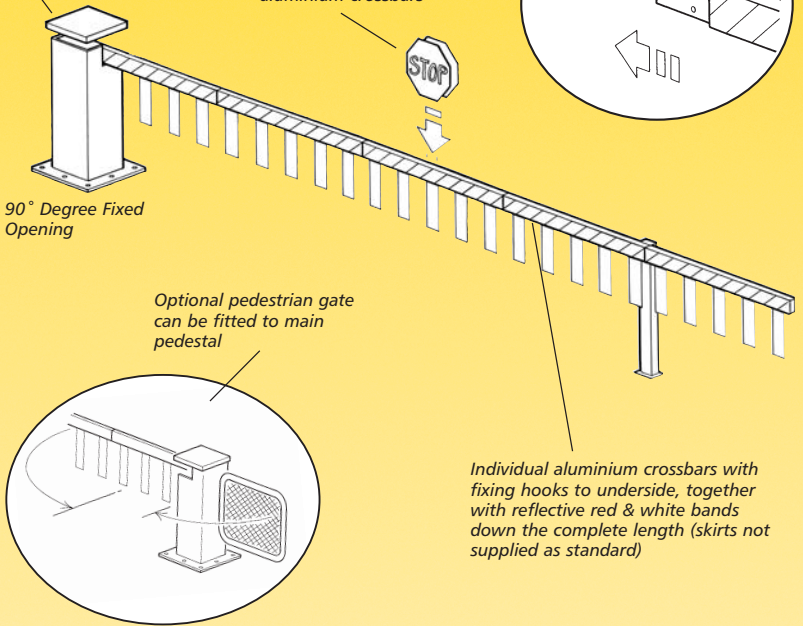

90° Degree Fixed  
Opening

Optional pedestrian gate  
can be fitted to main  
pedestal

Individual aluminium crossbars with  
fixing hooks to underside, together  
with reflective red & white bands  
down the complete length (skirts not  
supplied as standard)

- EASILY TRANSPORTED AND ASSEMBLED ON SITE •
- FAST TO OPEN AND CLOSE VIA FREE-RUNNING INTERNAL SWIVEL COUPLING DEVICE •
- ADAPTABLE TO SUIT VARYING ROAD WIDTHS •
- AVAILABLE AS TWIN BARRIER SETS OR SINGLE BARRIER SETS •
- PEDESTAL UNIT MANUFACTURED FROM MINIMUM 3MM STEEL PLATE & HOT DIP GALVANISED AFTER MANUFACTURE TO BS EN ISO 1461 •
- CROSS BAR AND SUPPORT LEG MANUFACTURED FROM ALUMINIUM •

## TYPE TSB1

### PRODUCT USES

A temporary safety barrier system for use when line/crossing maintenance takes place. Designed to be easily transported and temporarily assembled. Supplied as a pair of barriers, one each side of a typical level crossing.

### STANDARD PRODUCT FEATURES

- 90° fixed opening via free running internal swivel coupling device
- Can be padlocked in both open and closed positions
- Reflective bands down complete length of barriers to both front and back faces
- Fixing hooks to underside of each crossbar i.e. for attaching strip skirts
- Typical crossbar joint having one vertical and two horizontal connection bolts
- Double sided interchangeable hexagonal stop board sign positioned centrally as standard
- Supplied in sections for ease of transport and assembly on site
- Typical barrier comprises of: main pedestal unit with base plate, removable lid with two hasp & staple fixings, crossbar sections (number depending on road width) plus support leg
- Fast open and close action
- Optional strip skirts available (see accessories)
- Pedestal unit manufactured from minimum 3mm steel plate and hot dip galvanised after manufacture to BS EN ISO 1461
- Cross bar and support leg manufactured from Aluminium

### AVAILABILITY

Within 3 weeks (or to clients requirements) from receipt of order.

### ACCESSORIES

/skirt Strip skirts  
/gate Pedestrian gate

### HOW TO ORDER/SPECIFY

Progression example for specifying

1. Select Product Reference: TSB1
2. Add road width i.e. 6200mm =/620
3. Add accessory: i.e. /skirt

Full reference: TSB1/620/Skirt

## TEMPORARY SAFETY BARRIER

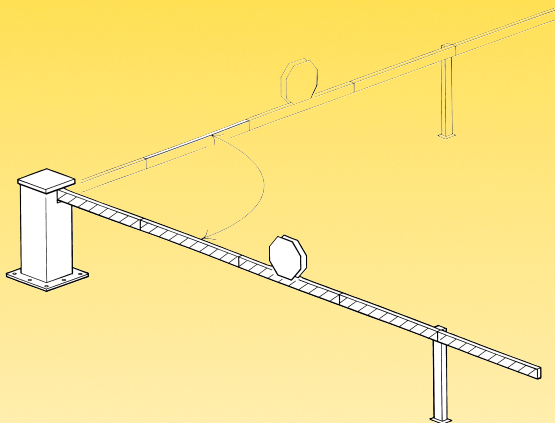

## SECTION/PLAN DETAILS

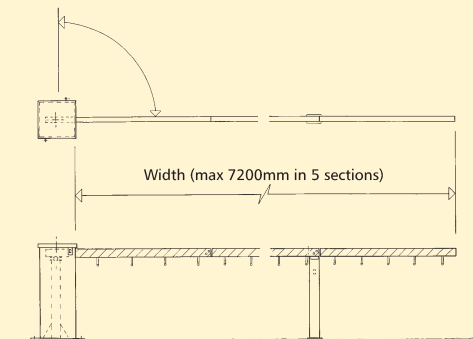

01/07/03

ALL TECHNICAL DETAILS ARE COPYRIGHT, AND MUST NOT BE REPRODUCED WITHOUT PRIOR CONSENT